

Sightglass light fittings in stainless steel for sterile applications in safe areas, series BKVLR A / BKVLR A LED, for mounting onto metal fused sightglasses

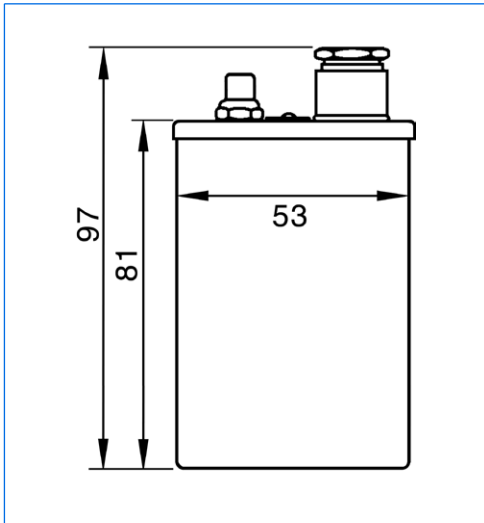

Sightglass light fitting type BKVLR 20 HDA, 20 W, 24 V, with built-in momentary push-button "D", on metal fused sightglass for aseptic flange connections to DIN 11864-2, DN 50



Dimensions

Branch office / exclusive agent:

All dimensions in mm. Subject to changes without preliminary notice.



The miniature sightglass light fittings BKVLR A / BKVLR A LED of the series STERI-LINE **entirely in stainless steel** offer the following main features:

- Very interesting prices due to high series production
- Only **one** size for use on different sightglass diameters
- **Brilliant and dazzle free illumination**, even of difficult media
- **Extremely small** dimensions providing **high lighting power**
- Quick change of the light source **without** necessity to demount the installed luminaire!

The series BKVLR A LED additionally offers the following advantages:

- State-of-the-art LED technology
- Insensitive to vibrations
- Suitable for continuous operation
- **Cold light outlet**
- **Very long life span** (up to approximately 20'000 - 50'000 operating hours)

Application:

On metal fused sightglasses and flanges (see the respective data sheet), mainly in the pharmaceutical, biotechnological and food processing industries.

Operating conditions:

Independent of internal vessel pressure and vacuum.

Construction:

Housing **in stainless steel**. Cable gland Pg 9, vertical. On request with rectangular cable gland ("K2"). Built-in reflector (series BKVLR A). Built-in push-button for momentary operation "D" (types BKVLR A 20/50 / BKVLR A LED also available **without**, on request). The light fitting is built to be mounted directly onto the collar of a sightglass fitted with the respective adapter. The sealing towards the sightglass is guaranteed by an O-ring being part of the adapter piece.

Technical data:

Type	BKVLR 20 HDA ¹	BKVLR 50 HDA ¹	BKVLR 100 HDA	BKVLR DA LED ¹
Power	20 W	50 W	100 W	Ca. 2 W
Terminal voltage ²	24 V AC / DC ³	24 V AC / DC ³	24 V AC / DC	24 V AC / DC
Maximum current	1,7 A	4,2 A	4,2 A	0,1 A
Light source	Halogene, socket G4	Halogene, socket GY 6.35	Halogene, socket GY 6.35	Diodes
Weight	0,30 kg	0,30 kg	0,30 kg	0,30 kg

¹ For the version **without** push-button, the correct type designation **omits** the "D".

² Transformers with 24 V secondary voltage in open design (IP 00) for mounting into control panels or switch boards as well as in closed version (IP 65) may be supplied for different primary voltages and power capacities.

³ Also available in 12 V AC / DC.

Enclosure protection degree:

IP 65, dust and spray water tight, to EN 60529 / DIN VDE 0470 part 1.

Mounting:

The light fitting is put onto the adapter ring of the respective sightglass and fixed by means of a hexagonal socket cap screw.

Important remarks:

Please indicate in case of order type and size (DN) of the sightglass on which the luminaire has to be mounted.

In case of repeated use of the series BKVLR A within a short period, the temperature raise of the housing has to be observed!

MAX MÜLLER AG

PROCESS ILLUMINATION AND VISUAL OBSERVATION SYSTEMS

Hagmattstrasse 19 • CH - 4123 Allschwil / Switzerland

Telephone +41 61 487 92 92 • Telefax +41 61 487 92 99

www.maxmuellerag.com E-Mail: blt@maxmuellerag.com

Sightglass light fittings from stainless steel

Series BKVLR A / BKVLR A LED for metal fused sightglasses for Triclamp fittings series metaClamp®



Light fitting miniLUX STERI-LINE, type BKVLR 20 HDA, 20 W, 24 V, mounted on metal fused sightglass, DN 50

Application:

On metal fused sightglasses for Triclamp fittings to DIN 32676 / ISO 2852 for the optimal illumination of small and pilot reactors as well as vessels for sterile and aseptic applications, mainly in the pharmaceutical, biotechnological, cosmetic and food processing industries. On demand also available for mounting on metal fused sightglasses for Triclamp fittings in aseptic version to DIN 11864-3.

Advantages:

- Brilliant and glare free illumination
- Extremely small dimensions
- For sterile applications
- High security
- Easy installation

The series BKVLR A LED additionally offers the following advantages:

- State-of-the-art LED technology
- Suitable for continuous operation
- Cold light outlet
- Very long life span (up to approximately 20'000 - 50'000 operating hours)

Light fitting series miniLUX STERI-LINE (for safe areas only):

Supply: Alternative or direct current (AC / DC)
 24 V (Standard), 12 V (Option for the types BKVLR A 20 / 50)

Power: 20, 50, 100 W (BKVLR A), ca. 2 W (BKVLR A LED)

Housing: Stainless steel

Light source: Halogen (BKVLR A) / Diodes (BKVLR A LED)

Protection mode: IP 65, dust and spray water tight to EN 60529 / DIN VDE 0470 part 1

For more technical details see data sheet miniLUX STERI-LINE, series BKVLR A / BKVLR A LED

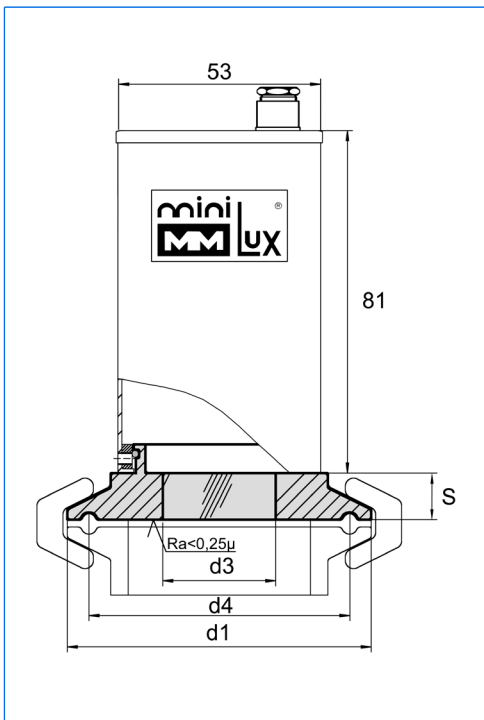

Dimensions with mounted light fitting

All dimensions in mm. Subject to changes without preliminary notice.

Metal fused sightglass:

Approvals:

A3 Standard for food processing

Technical data:

- Test base: DGRL 97 / 23 / EG, AD 2000 standards, DIN 7079-1 May 1999
- Materials to VdTÜV specifications and the respective DIN/EN standards
- Glass quality: Borosilicate glass to DIN 7080

Certificates:

- To be supplied against extra charge to DIN EN 10204

Operating conditions:

- Pressure: -1 to 10 / 16 bar (see table)
- Temperatures: Ring materials:

1.4462:	-30 °C to +280 °C
2.4602:	-60 °C to +300 °C
2.4610:	-60 °C to +300 °C

Dimensions:

Nominal diameter			d1	d3	d4	S	Max. operating pressure (bar)
DN to DIN	DN to ISO	Inch					
25 / 32 / 40	20 / 25	1", 1½"	50,5	25	43,5	12	16
50	40	2"	64	30	56,5	12	16
-	50	2½"	77,5	34	70,5	12	10
65	65	3"	91	35	83,5	12	10

Sightglass light fittings from stainless steel

Series BKVLR A / BKVLR A LED on metal fused sightglasses for aseptic connections to DIN 11864-1



Light fitting miniLUX STERI-LINE, type BKVLR DA LED, ca. 2 W, 24 V, mounted on metal fused sightglass to DIN 11864-1

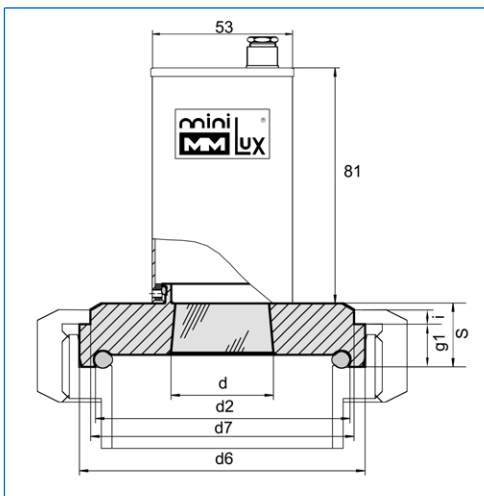

Dimensions with mounted light fitting

Branch office / exclusive agent:

Application:

On metal fused sightglasses for aseptic connections to DIN 11864-1 for the optimal illumination of small and pilot reactors as well as vessels for sterile and aseptic applications, mainly in the pharmaceutical, biotechnological, cosmetic and food processing industries.

Advantages:

- Brilliant and glare free illumination
- Extremely small dimensions
- Aseptic
- High security
- Easy installation
- CIP and SIP cleaning possible

The series BKVLR A LED additionally offers the following advantages:

- State-of-the-art LED technology
- Suitable for continuous operation
- Cold light outlet
- Very long life span (up to approximately 20'000 - 50'000 operating hours)

Light fitting series miniLUX STERI-LINE (for safe areas only):

Supply: Alternative or direct current (AC / DC)
 24 V (Standard), 12 V (Option for the types BKVLR A 20 / 50)
 Power: 20, 50, 100 W (BKVLR A), ca. 2 W (BKVLR A LED)
 Housing: Stainless steel
 Light source: Halogen (BKVLR A) / Diodes (BKVLR A LED)
 Protection mode: IP 65, dust and spray water tight to EN 60529 / DIN VDE 0470 part 1

For more technical details see data sheet miniLUX STERI-LINE, series BKVLR A / BKVLR A LED

Metal fused sightglass:

Technical data:

- Test base: DGRL 97 / 23 / EG, AD 2000 standards, DIN 7079-1 May 1999
- Materials to VdTÜV specifications and the respective DIN / EN standards
- Glass quality: Borosilicate glass to DIN 7080

Certificates:

- To be supplied against extra charge to DIN EN 10204

Operating conditions:

- Pressure: -1 to 25 bar
- Temperatures: Ring materials:

1.4462:	-30 °C to +280 °C
2.4602:	-60 °C to +300 °C
2.4605:	-60 °C to +300 °C
2.4610:	-60 °C to +300 °C

Dimensions:

DN	PN	d2	d6	d7	d	g1	S	O-Ring
40	25	48,66	54,9	48	28	10	14	40 x 5,0
50	25	60,66	66,9	61	34	11	15	52 x 5,0
65	25	76,66	84,9	79	37	12	15	68 x 5,0
80	25	91,66	98,9	93	37	12	18	83 x 5,0
100	25	110,66	118,9	114	37	15	21	102 x 5,0

All dimensions in mm. Subject to changes without preliminary notice.



MAX MÜLLER AG

PROCESS ILLUMINATION AND VISUAL OBSERVATION SYSTEMS

Hagmattstrasse 19 • CH - 4123 Allschwil / Switzerland

Telephone +41 61 487 92 92 • Telefax +41 61 487 92 99

www.maxmuellerag.com E-Mail: blt@maxmuellerag.com

Sightglass light fittings from stainless steel

Series BKVLR A / BKVLR A LED on metal fused sightglasses for aseptic connections to DIN 11864-2



Light fitting miniLUX STERI-LINE, type BKVLR 20 HDA, 20 W, 24 V, mounted on metal fused sightglass to DIN 11864-2, DN 50

Application:

On metal fused aseptic grooved flanges for mounting onto aseptic flanges of the form A for the optimal illumination of small and pilot reactors as well as vessels for sterile and aseptic applications, mainly in the pharmaceutical, biotechnological, cosmetic and food processing industries.

Advantages:

- Brilliant and glare free illumination
- Extremely small dimensions
- The sightglass and the form of the gasket correspond to the recommendations of the EHEDG (European Hygienic Equipment Design Group)
- To ASME BPE 2002 (Bioprocessing Equipment)
- Fulfil the requirements of the GMP regulations regarding property, cleaning and possibility of sterilisation
- High security
- CIP and SIP cleaning possible

The series BKVLR A LED additionally offers the following advantages:

- State-of-the-art LED technology
- Suitable for continuous operation
- Cold light outlet
- Very long life span (up to approximately 20'000 - 50'000 operating hours)

Light fitting series miniLUX STERI-LINE (for safe areas only):

Supply: Alternative or direct current (AC / DC)
 24 V (Standard), 12 V (Option for the types BKVLR A 20 / 50)

Power: 20, 50, 100 W (BKVLR A), ca. 2 W (BKVLR A LED)

Housing: Stainless steel

Light source: Halogen (BKVLR A) / Diodes (BKVLR A LED)

Protection mode: IP 65, dust and spray water tight to EN 60529 / DIN VDE 0470 part 1

For more technical details see data sheet miniLUX STERI-LINE, series BKVLR A / BKVLR A LED

Metal fused sightglass:

Technical data:

- Test base: DGRL 97 / 23 / EG, AD 2000 standards, DIN 7079-1 May 1999
- Materials to VdTÜV specifications and the respective DIN/EN standards
- Glass quality: Borosilicate glass to DIN 7080

Certificates:

- To be supplied against extra charge to DIN EN 10204

Operating conditions:

- Pressure: -1 to 16 bar
- Temperatures: Ring materials:

1.4462:	-30 °C to +280 °C
2.4602:	-60 °C to +300 °C
2.4610:	-60 °C to +300 °C

Dimensions:

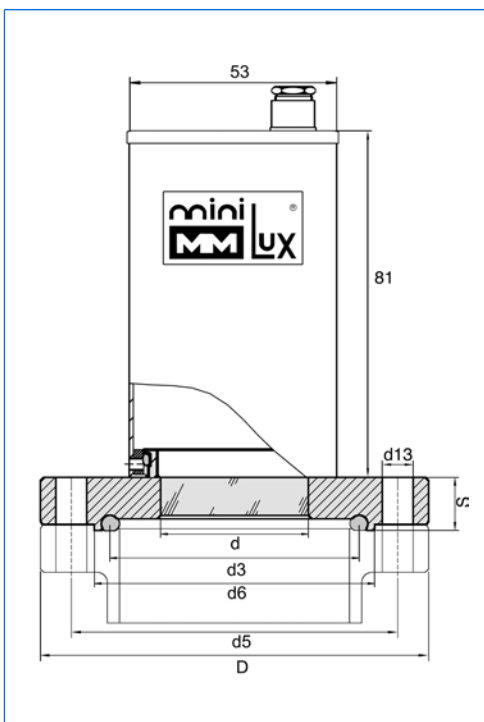

Dimensions with mounted light fitting

All dimensions in mm. Subject to changes without preliminary notice.

Nominal diameter DN			PN	D	d	d3	d5	d6	d13	S	O-Ring
DIN 11850	ISO 1127	ISO 2037 BS 4825									
-	48,3	-	16	88	34	50,95	71	59,9	4 x ø9	14	46,5 x 5
-	-	2"	16	92	34	54,45	75	63,4	4 x ø9	16	50 x 5
50	-	-	16	94	34	56,65	77	65,6	4 x ø9	16	52 x 5
-	60,3	-	16	103	34	62,95	85	71,9	4 x ø9	16	58,5 x 5
-	-	2½"	16	107	34	66,85	89	75,8	8 x ø9	18	62 x 5
65	-	-	16	113	34	72,65	95	81,6	8 x ø9	18	68 x 5
-	76,1	-	16	125	34	78,35	104	88,1	8 x ø11	20	73,5 x 5
-	-	3"	16	125	34	79,55	104	89,5	8 x ø11	20	75 x 5
80	-	-	16	133	34	87,65	112	97,6	8 x ø11	20	83 x 5
-	88,9	-	16	137	34	90,95	116	100,9	8 x ø11	20	86,5 x 5



MAX MÜLLER AG

PROCESS ILLUMINATION AND VISUAL OBSERVATION SYSTEMS

Hagmattstrasse 19 • CH - 4123 Allschwil / Switzerland

Telephone +41 61 487 92 92 • Telefax +41 61 487 92 99

www.maxmuellerag.com E-Mail: blt@maxmuellerag.com

Sightglass light fittings from stainless steel

Series BKVLR A / BKVLR A LED for metal fused sightglasses for NA-Connect™-connections



Light fitting miniLUX STERI-LINE, type BKVLR DA LED, ca. 2 W, 24 V, mounted on metal fused sightglass NA-Connect™, DN 50

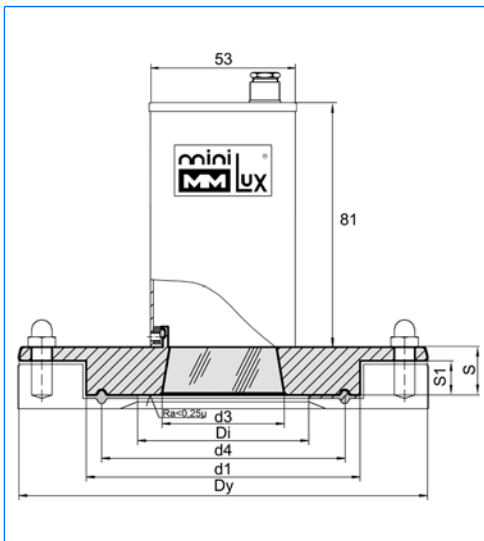

Dimensions with mounted light fitting

Branch office / exclusive agent:

Application:

On metal fused sightglasses for NA-Connect™-connections for the optimal illumination of small and pilot reactors as well as vessels for sterile and aseptic applications, mainly in the pharmaceutical, biotechnological, cosmetic and food processing industries.

Advantages:

- Brilliant and glare free illumination
- Extremely small dimensions
- High security
- Easy installation
- For sterile applications
- CIP cleaning possible

The series BKVLR A LED additionally offers the following advantages:

- State-of-the-art LED technology
- Suitable for continuous operation
- Cold light outlet
- Very long life span (up to approximately 20'000 - 50'000 operating hours)

Light fitting series miniLUX STERI-LINE (for safe areas only):

Supply: Alternative or direct current (AC / DC)
 24 V (Standard), 12 V (Option for the types BKVLR A 20 / 50)

Power: 20, 50, 100 W (BKVLR A), ca. 2 W (BKVLR A LED)

Housing: Stainless steel

Light source: Halogen (BKVLR A) / Diodes (BKVLR A LED)

Protection mode: IP 65, dust and spray water tight to EN 60529 / DIN VDE 0470 part 1

For more technical details see data sheet miniLUX STERI-LINE, series BKVLR A / BKVLR A LED

Metal fused sightglass:

Technical data:

- Test base: DGRL 97 / 23 / EG, AD 2000 standards, DIN 7079-1 May 1999
- Materials to VdTÜV specifications and the respective DIN/EN standards
- Glass quality: Borosilicate glass to DIN 7080

Certificates:

- To be supplied against extra charge to DIN EN 10204

Operating conditions:

- Temperatures: Ring materials: 1.4462: -30 °C to +280 °C
 2.4602: -60 °C to +300 °C
 2.4610: -60 °C to +300 °C

NA-Connect™:

Materials welding flange: 316 L / 1.4435
 Nominal pressure: 7 bar (PN 7)
 Nominal temperature: 150 °C

Dimensions:

Nominal diameter		NA-Connect welding flange		d1	d3	d4	S1	S	Dy	Di
Inch	DN	DIN	Tube OD							
1" / 1½"	25 / 32 / 40	NAC-DIN-40	NAC-OD-1½"	50,5	30	43,5	7	13	85	35,5
2"	50	NAC-DIN-50	NAC-OD-2"	64,0	35	56,5	8	14	100	48,5
2½"	-	-	NAC-OD-2½"	77,5	35	70,5	8	15	112	60,2
3"	65	NAC-DIN-65	NAC-OD-3"	91,0	35	83,5	8	18	131	72,0

All dimensions in mm. Subject to changes without preliminary notice.



MAX MÜLLER AG

PROCESS ILLUMINATION AND VISUAL OBSERVATION SYSTEMS

Hagmattstrasse 19 • CH - 4123 Allschwil / Switzerland

Telephone +41 61 487 92 92 • Telefax +41 61 487 92 99

www.maxmuellerag.com E-Mail: blt@maxmuellerag.com

Sightglass light fittings from stainless steel for sterile applications

Series BKVLR A / BKVLR A LED on metal fused sightglass flanges for sterile processes



Light fitting miniLUX STERI-LINE, type BKVLR 20 HDA, 20 W, 24 V, mounted on a metal fused sightglass flange for sterile applications, DN 50

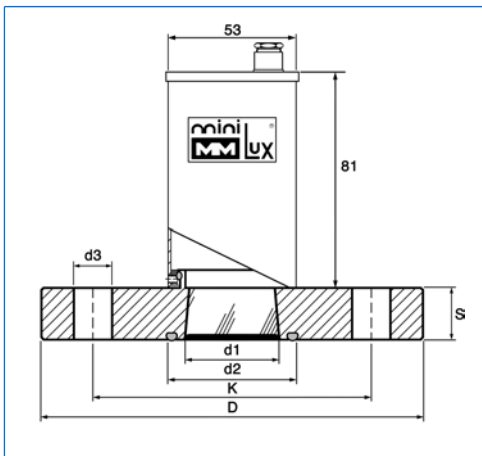

Dimensions

Branch office / exclusive agent:

Application:

On metal fused sightglass flanges for mounting onto

- base flanges to DIN 28117 or similar
- weldnecks with flat face

for the optimal illumination of small and pilot reactors as well as vessels for sterile and aseptic applications, mainly in the pharmaceutical, biotechnological, cosmetic and food processing industries.

IMPORTANT: Only for use with parallel flat face flanges without seal recess. We recommend the use of Belleville spring washers, 2 pcs. for each connection hole.

Advantages:

- Brilliant and glare free illumination
- Extremely small dimensions
- Aseptic
- High security
- Easy installation
- CIP and SIP cleaning possible

The series BKVLR A LED additionally offers the following advantages:

- State-of-the-art LED technology
- Suitable for continuous operation
- Cold light outlet
- Very long life span (up to approximately 20'000 - 50'000 operating hours)

Light fitting series miniLUX STERI-LINE (for safe areas only):

Supply:	Alternative or direct current (AC / DC)
Power:	24 V (Standard), 12 V (Option for the types BKVLR A 20 / 50)
Housing:	20, 50, 100 W (BKVLR A), ca. 2 W (BKVLR A LED)
Light source:	Stainless steel
Protection mode:	Halogen (BKVLR A) / Diodes (BKVLR A LED)
	IP 65, dust and spray water tight to EN 60529 / DIN VDE 0470 part 1

For more technical details see data sheet miniLUX STERI-LINE, series BKVLR A / BKVLR A LED

Metal fused sightglass flange:

Technical data:

- Test base: DGRL 97 / 23 / EG, AD 2000 standards, DIN 7079-1 May 1999
- Materials to VdTÜV specifications and the respective DIN/EN standards
- Glass quality: Borosilicate glass to DIN 7080

Certificates:

- To be supplied against extra charge to DIN EN 10204

Operating conditions:

- Pressure: -1 to 16 bar
- Temperatures: Ring materials:

1.4462:	-30 °C to +280 °C
2.4602:	-60 °C to +300 °C
2.4605:	-60 °C to +300 °C
2.4610:	-60 °C to +300 °C

Dimensions:

DN*	PN	D	K	S	d1	d2	d3	Number of holes	O-Ring**	Spring washer**
50	16	165	125	21	38	66	18	4	58,74 x 3,53	31,5/16,3x1,25
65	16	185	145	23	38	86	18	4	78,97 x 3,53	31,5/16,3x1,25

* Larger nominal diameters on request

** Not contained in our delivery

All dimensions in mm. Subject to changes without preliminary notice.



MAX MÜLLER AG

PROCESS ILLUMINATION AND VISUAL OBSERVATION SYSTEMS

Hagmattstrasse 19 • CH - 4123 Allschwil / Switzerland

Telephone +41 61 487 92 92 • Telefax +41 61 487 92 99

www.maxmuellerag.com E-Mail: blt@maxmuellerag.com