

Metal fused sightglasses with wipers series WD for Triclamp fittings

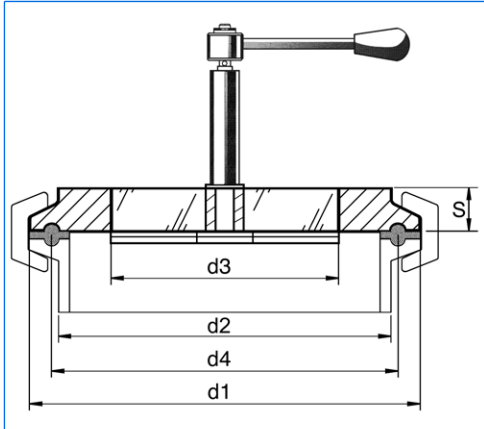

Sightglass for Triclamp fitting with built-in wiper, series WD



Typical assembly

Branch office / exclusive agent:

Application:

- For clamp fittings to DIN 32676 / ISO 2852

Advantages:

- For sterile applications
- High security
- Easy installation

Technical data:

- Test base: DGRL 97 / 23 / EG, AD 2000 standards, DIN 7079-1 May 1999
- Ring materials to VdTÜV specifications and the respective DIN / EN standards

Certificates:

- To be supplied against extra charge to DIN EN 10204-3.1

Operating conditions:

- Pressure: -1 to 6 bar
- Temperature: Maximum 150°C

Materials:

- Ring: 1.4462, 2.4602 (other materials on demand)
- Fused bush: 1.3912 (Alloy 36)
- Glass disc: Borosilicate glass to DIN 7080
- Wiper: PTFE or silicone rubber
- Wiper blade: PTFE or silicone rubber
- Mechanical parts: Stainless steel (contact parts)
- O-rings: Viton
- Operated by: Handling arm with free-wheel return drive

Dimensions:

Nominal diameter (DN)		d1	d2	d3	d4	S	Max. operating pressure (bar)
(mm)	(inch)						
65 *	3"	91	76	40	83,5	10	6
80 *	3½"	106	90	50	97	10	6
100 *	4"	119	101	55	110	12	6
-	6"	167	152	75	156,5	16	6
150	-	183	160	75	174,3	16	6
-	8"	217,5	198	100	207,4	18	6
200	-	233,5	210	100	225,1	18	6
-	10"	268	245	120	257,8	20	6
250	-	287,5	266	120	278,4	20	6
-	12"	319,3	300	140	309,1	22	6
300	-	338,3	316	140	328,4	22	6

* Not recommended since extremely little viewing surface

All dimensions in mm. Subject to changes without preliminary notice.